

# EGPL-21S3

## M.2 2230 to Single Isolated 2.5GbE LAN Module

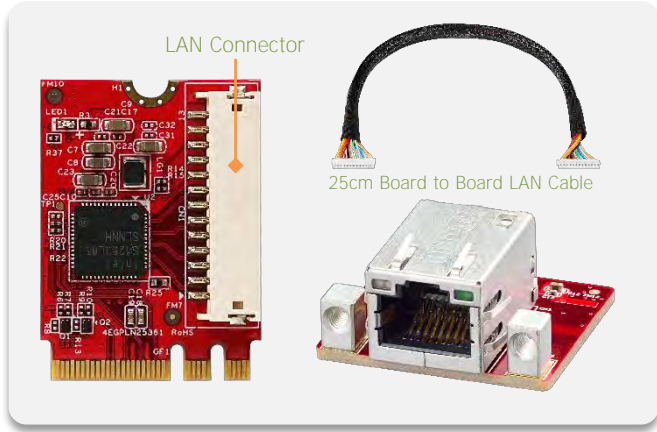

### Features

- Single isolated 2.5GbE LAN ports
- Complies with EN61000-4-5 2kV surge protection
- Complies with IEC 60950-1:2005 + A1: 2009 + A2:2013 2kV HiPOT protection
- Complies with EN61000-4-2 (ESD) Air-15kV, Contact-8kV
- Flexible daughter board with cable to fit into different system
- Industrial temperature -40 °C to 85 °C

### Mechanical Drawing

#### Main Board

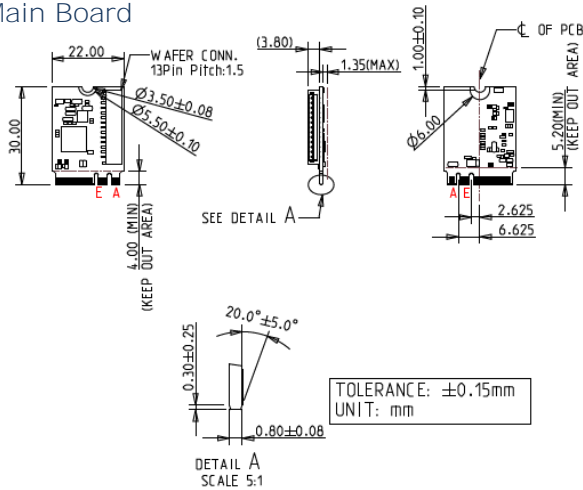

#### Daughter Board

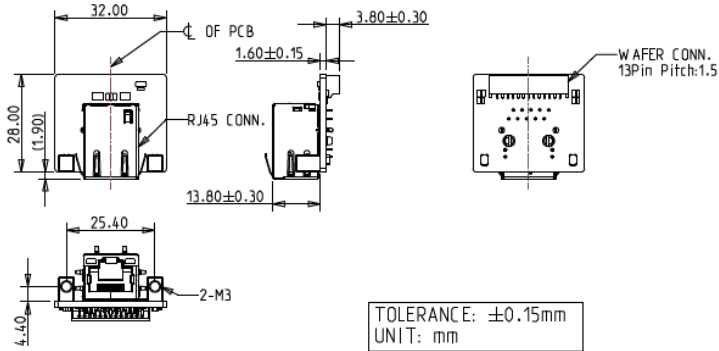

### Specifications

Form-Factor	M.2 2230 A-E
Input I/F	PCI Express 2.1 x 1
Output I/F	Single 2.5GbE LAN
Output Connector	RJ45 x 1
Power Consumption	MAX: 1.072W (3.3V, 325mA)
Dimension (WxLxH)	Main board: 22 x 30 x 5.95 mm Daughter board: 32x 28 x 19.2mm
Temperature	Operation: STD: 0°C ~ +70°C. W/T: -40°C ~ +85°C Storage: -55°C ~ +95°C
Environment	Vibration: 5G @7~2000Hz, Shock: 50G @ 0.5ms
Notes	Please download driver from Intel official website. Windows: 10 (64bit), Linux (igc): kernel 5.x version
Limitations	*Linux upstream kernel release – from 5.16.18 *Not recommend used in VMware ESXi due to High Latency *Not support Intel vPro

### Order information

EGPL-21S3-C1 (Mounting hole, Standard Temp.)

EGPL-21S3-W1 (Mounting hole, Wide Temp.)

M.2 2230 to Single Isolated 2.5GbE LAN Module