

CFast 3IE7 series

Drawing

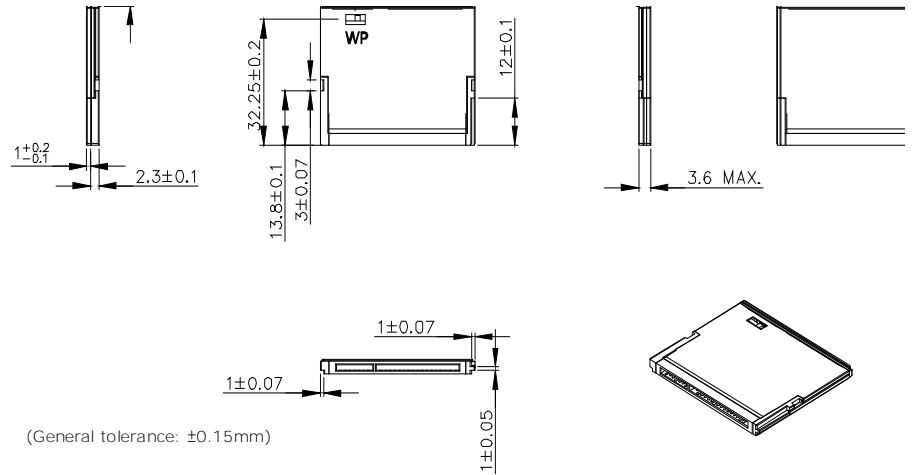

Specifications

Interface	SATA III
Flash Type	iSLC
Capacity	20GB~160GB
Max. Channels	4
Sequential R/W (MB/sec, max.)	550/490
Max. Power Consumption	1.4 W
Thermal Sensor	√
External DRAM Buffer	-
H/W Write Protect	Optional*
ATA Security	√
S.M.A.R.T.	√
Dimension (WxLxH)	42.8X 36.4 X 3.6 mm
Environment	Vibration: 20G @7~2000Hz Shock: 1500G @ 0.5ms Storage Temperature: -40°C ~ +85°C MTBF: 3 million hours

Ordering Information

Operation Temp.	20GB	40GB	80GB	160GB
Standard Grade (0°C ~ +70°C)	DHCFA-20GDK1EC1DF(W)	DHCFA-40GDK1EC1QF(W)	DHCFA-80GDK1EC1QF(W)	DHCFA-A60DK1EC1QF(W)
Industrial Grade (-40°C ~ +85°C)	DHCFA-20GDK1EW1DF(W)	DHCFA-40GDK1EW1QF(W)	DHCFA-80GDK1EW1QF(W)	DHCFA-A60DK1EW1QF(W)

*H/W write protect function is optional.

(For the write protect demand, please place the order by PN: DHCFA-xxxDK1GxAxFW)

* D: Dual channel / Q: four channel