

# AIMB-292

## 12/13/14th Gen Intel® Core™ Processor Nvidia MXM GPU Integration



### Features

- 12/13/14th Gen Intel® Core™ Desktop Processors, max. 24Core, support Q670E chipset
- Integrated NVIDIA MXM Graphics
- Up to 96GB DDR5 5600 MT/s with two SO-DIMM
- Quadruple displays with 3 DP and 1 LVDS (or eDP), up to 4K
- Abundant Expansion: 1 M.2 M-key & 1 M.2 E-key (B-key by option), 4 USB 3.2 Gen2x1, 2 USB 2.0, 1 SATA III
- Qualified for Edge AI SRP of WISE-DeviceOn and Embedded Software APIs

#### Software APIs:



#### Utilities:



### Specifications

14th Generation Processors	CPU	i9-14900	i9-14900T	i7-14700	i7-14700T	i5-14500	i5-14500T	i5-14400	i5-14400T	i3-14100	i3-14100T		
	Core Number	24	24	20	20	14	14	10	10	4	4		
	Base frequency (GHz)	2	1.1	2.1	1.3	2.6	1.7	2.5	1.5	3.5	2.7		
	Max Speed (GHz)	5.4	5.1	5.3	5	5	4.8	4.7	4.5	4.7	4.4		
	Smart cache (MB)	36	36	33	33	24	24	20	20	12	12		
TDP (W)	65	35	65	35	65	35	65	35	60	35			
13th Generation Processors	CPU	i9-13900E / i9-13900	i9-13900TE	i7-13700E / i7-13700	i7-13700TE	i5-13500E / i5-13500	i5-13500TE	i5-13400E / i5-13400	i3-13100E / i3-13100	i3-13100TE			
	Core Number	24	24	16	16	14	14	10	4	4			
	Base frequency (GHz)	1.8/2.0	1	1.9/2.1	0.8	2.4/2.6	1.3	2.4/2.5	3.3/3.4	2.4			
	Max Speed (GHz)	5.2/5.6	5	5.1/5.2	4.8	4.6/4.8	4.5	4.6	4.4/4.5	4.1			
	Smart cache (MB)	36	36	30	30	24	24	20	12	12			
TDP (W)	65	35	65	35	65	35	65	60	35				
12th Generation Processors	CPU	i9-12900E / i9-12900	i9-12900TE	i7-12700E / i7-12700	i7-12700TE	i5-12500E / i5-12500/12400	i5-12500TE	i3-12100E / i3-12100	i3-12100TE	G7400E	G7400TE	G6900E	G6900TE
	Core Number	16	16	12	12	6	6	4	4	2	2	2	2
	Base frequency (GHz)	2.3/2.4	1.1	2.1	1.4	2.9/3.0/2.5	1.9	3.2	2.1	3.6	3	3	2.4
	Max Speed (GHz)	5	4.8	4.8	4.7	4.5/4.6/4.4	4.3	4.2/4.3	4	NA	NA	NA	NA
	Smart cache (MB)	30	30	25	25	18	18	12	12	6	6	4	4
TDP (W)	65	35	65	35	65	35	60	35	46	35	46	35	
Processor System	Chipset	Q670E											
	BIOS	AMI EFI 256 Mbit SPI											
Expansion Slot	M.2	1 x M-key (2280, for NVMe Storage) 1 x E-key (2230, for WiFi/BT) or 1 x B-key (3042, only for LTE) by option											
Memory	Technology	Dual Channel DDR5, up to 5600 MT/s (non-ECC)											
	Max. Capacity	96GB (up to 48GB per DIMM)											
	Socket	2 x 262 pin DDR5 SO-DIMM											
Graphics	Native GPU	Intel® UHD Graphics 770											
	Discrete GPU	Quadro® A4500											
	Cores	5,888 CUDA® cores											
	FP32 Performance	17.66 (TFLOPS)											
	Memory	GDDR6 16GB											
Display	DP	2 x DP from MXM Type-A/B/B+ module: DP 1.4a, up to 4K at 120Hz 1 x DP ++ from CPU: up to 4096 x 2160 @60 Hz											
	LVDS or eDP	1 (by pass mode), LVDS up to 1920x1200@60Hz, eDP up to 1920x1080@60Hz											
	Multi Displays	Quadruple independent display. Onboard: DP++/LVDS or eDP Onboard + MXM Type-A/B/B+ module: DP++/LVDS or eDP + DP + DP											
Network	Ethernet	10/100/1000/2500 Mbps											
	Controller	LAN1: 2.5 GbE Intel I226-V LAN2: 2.5 GbE Intel I226-V LAN3: 1 GbE Intel I210-AT											
	Connector	3 x RJ45											
Audio	Codec	Realtek ALC888S, High Definition Audio (HD), Line-Out (default)											
	Amplifier	Yes (Option, 3.2W)											

### Specifications (Cont.)

SATA	Max data transfer rate	6.0 Gb/s		
	Channel	1 (SATA III)		
Rear I/O	DP	3		
	Ethernet	3		
	USB	4 x USB 3.2 Gen2x1		
	Audio	1 (Line out by default, Line in/Line out/Mic in programmable)		
	Power Connector	1 x Terminal block (4P, Phoenix Contact)		
Internal Connector	USB	2 x USB 2.0		
	LVDS/eDP	1 (LVDS or eDP by pass mode)		
	Serial	2 (RS-232/422/485 with auto flow control)		
	SATA	1		
	M.2	1 x M-key (2280, for NVMe Storage) 1 x E-key (2230, for WiFi/BT) or 1 x B-key (3042, only for LTE) by option		
	GPIO	8-bit		
Watchdog Timer	Output	System reset		
	Interval	Programmable 1 ~ 255 (second or minute)		
Power Requirements	Input voltage	24V DC-in		
	Connector	4-pin Terminal block		
	Power consumption	Configuration	Intel® Core™ i9-14900, 2pcs 48 GB DDR5 5600 MT/s	
		Max.	100.2 W	
Typical	62.5 W			
Environment	Temperature	Operating	Non-Operating	
	Storage	0 ~ 55° C (32 ~ 131° F), depends on STD or THIN GPU cooler		
Physical Characteristics	Dimensions	170 mm x 230 mm (6.69" x 9.06")		

### Block Diagram

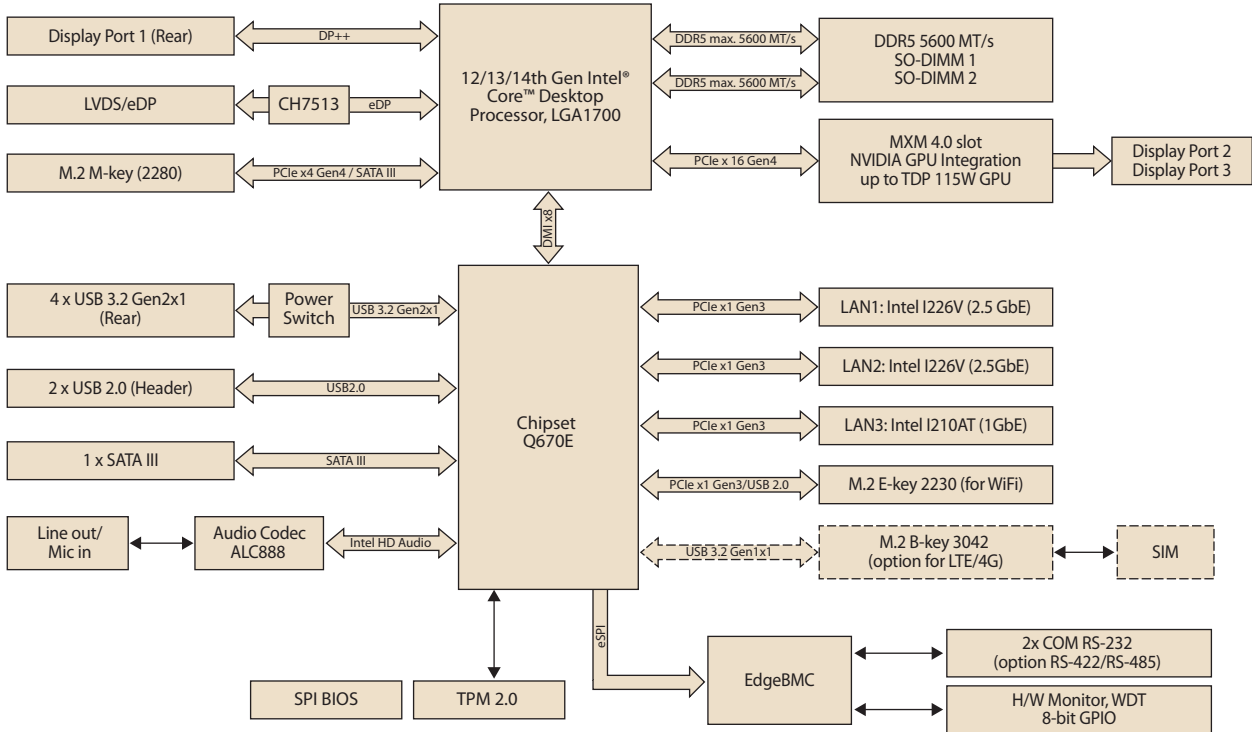

## Ordering Information

P/N	GPU	DP	LVDS/ eDP	2.5 GbE	GbE	COM	SATA III	USB 3.2	USB 2.0	M.2 M-key	M.2 E-key	TPM 2.0	AMP	Cooler type	Temperature
AIMB-292Q-00A1	Quadro® A4500	3	1	2	1	2	1	4	2	1	1 (option B-key)	1	1	Standard	0-55°C

\*() Supports by BOM options

### AIMB-292 Kit

P/N	GPU	CPU	Memory	Storage	DP	LVDS/ eDP	2.5 GbE	GbE	COM	SATA III	USB 3.2	USB 2.0	M.2 M-key	M.2 E-key	TPM 2.0	AMP	Cooler type	Temperature
AIMB-292Q-K1A1	Quadro® A4500	i7-13700E	32GB	512G NVMe	3	1	2	1	2	1	4	2	1	1 (option B-key)	1	1	THIN cooler	0-55°C

## Packing List

P/N	Description	Quantity
1700003194	SATA HDD cable	1
1700018785	SATA power cable (1 port, 25cm)	1
1700034404-02	1-to-1 serial port cable, 50cm	1
1960116131T001	I/O port bracket	1
AIMB-292 Board	Assembly of AIMB-292 and MXM module	1
1930005673-11	M.2 screw (3x4.5L)	2

## Optional Accessories

Part Number	Description

## Embedded OS/API

OS/API	Part No.	968 P/N	Description

## I/O View



# Reliable Embedded BIOS Solutions

Custom BIOS services with long-term support

Advantech's high-quality embedded BIOS solutions deliver rapid execution and feature expert BIOS team support. These solutions feature multi-functional designs that ensure security and enable power/boot management. Advantech further provides 10+ years of BIOS version management, internal management, and longevity support for both hardware and BIOS — enhancing application efficiency, diversifying functionality, and optimizing performance.

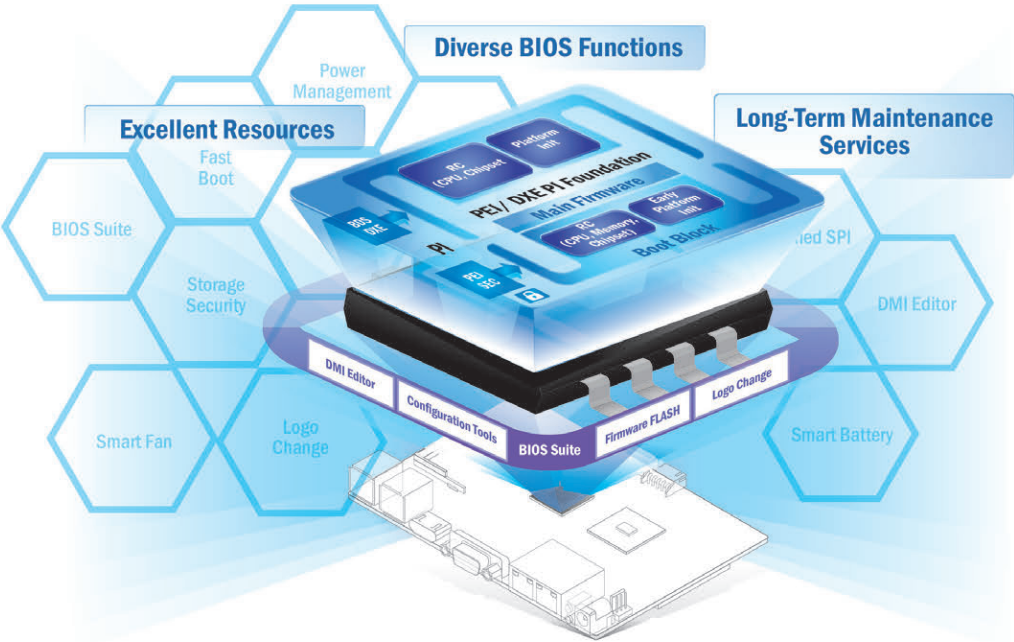

## Embedded BIOS Solution Advantages

### Sufficient Sources

- Strong partnership with BIOS vendors
- 50+ engineers with extensive industrial BIOS experience

### Diverse BIOS Functions

- Multi-layer security
- 3 second fast boot
- Power management
- BIOS suite utility

### Long-Term Maintenance Services

- Platform longevity support
- 10-year BIOS version control
- BIOS remote backup

## Value-Added Customization Process



# WISE-DeviceOn

## Edge AI OTA and Container Management

### WISE-DeviceOn End-to-End Solution for Edge AI

Even if all datasets, algorithms, trainings, UI/UX, and more are functioning, how can you easily deploy an AI application to hundreds, or thousands, of inference devices in production? How can you efficiently manage AI models (software updates, CI/CD), in addition to all remote, hardware devices, such as sensors?



### Solution Advantages



#### Performance Booster

- Inference optimization
- Open Neural Network Compiler (ONNC)
- Save over 45% DRAM consumption



#### Fleet Management

- Remote batch control for power management, reboot, terminal and screenshot
- Real-time monitoring, diagnostics and notification
- Over 10,000 devices around the globe



#### Container and OTA

- Streamlined deployment process
- Docker container management
- Software OTA (over-the-air) updates



#### AI Security

- AI containers deployed via Azure Container Registry and Harbor
- Secured data connection (TLS/SSL)
- Integrity protection based on digital signature

# Edge AI Suite

AI development for diverse application at the Edge

Increasing demand for AI inference/analytic capabilities at the Edge make AI training models, software development environments, and hardware configuration key factors in successful solution deployment. Advantech's Edge AI Suite helps users build AI demo devices quickly and choose optimal hardware solutions easily.



5x Performance Boost	All-in-one Installation	One Click AI Experience	Plug-and-play Environment	Discover Cost-effective Hardware
<ul style="list-style-type: none"><li>Integrated Intel® OpenVINO™ technology</li><li>Boost AI using Advantech hardware</li></ul>	<ul style="list-style-type: none"><li>Build AI environment in under 5 minutes</li><li>Ready-to-use configuration</li></ul>	<ul style="list-style-type: none"><li>User friendly configuration guidance</li><li>One-click Benchmark acquisition</li></ul>	<ul style="list-style-type: none"><li>Easy access to 100+ AI inference extensions</li><li>Software development package available</li></ul>	<ul style="list-style-type: none"><li>Diverse CPU/RAM options</li><li>Find hardware solutions for AI development</li></ul>

# Embedded Linux Support and Design-in Services

## Hardware Certified Ubuntu and Yocto with Eco Partner Services

Linux is the most popular embedded OS for transportation, outdoor services, factory automation, and mission critical applications. Its open source and kernel reliability features ease security updates, and make it particularly adaptable to new AI and Edge computing technology. Advantech has cooperated with Canonical and other software partners to provide hardware certified Ubuntu image and Yocto BSP as Linux offerings. The Advantech, Embedded Linux, and Android Alliance (ELAA) delivers local software services and consultation.



### Features

Certified OS and BSP	Licensed Services	Numerous AI and Edge Resources	Local Partner Alliance
<ul style="list-style-type: none"> <li>Platform compatibility tests</li> <li>Preloaded functional driver and software stacks</li> </ul>	<ul style="list-style-type: none"> <li>License authorized Canonical delivers 10-years of bug fixes and security updates</li> <li>In-house bundled service</li> </ul>	<ul style="list-style-type: none"> <li>Containerized technology for service provision and deployment</li> <li>AI resources from Caffe, TensorFlow, and mxnet</li> </ul>	<ul style="list-style-type: none"> <li>Embedded Linux and Android Alliance (ELAA)</li> </ul>