

# W15L100-PTA3-ME

## 15.6" Multi-Touch Color Surgical Display

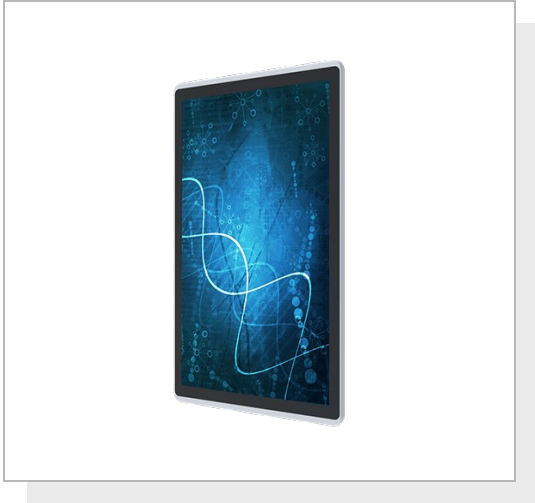

### KEY FEATURES

- 15.6" 1920 x 1080 Resolution Display, Medical Grade Computers
- Projected Capacitive Multi-touch
- VGA input and HDMI input
- Stylish and elegant design
- Housing with antimicrobial properties
- Front IP65 Multi-Touch Color Surgical Display



### SPECIFICATIONS

Display			
<b>Touch / Glass</b>	Projected Capacitive Multi Touch Screen	<b>Resolution</b>	1920x1080
<b>Size</b>	15.6 inches	<b>Contrast Ratio</b>	800:1
<b>Panel Brightness</b>	400 nits	<b>Display Color</b>	262K Colors
<b>View Angles</b>	85,85,85,85	<b>Active Area</b>	344.16 ×193.59 mm
Environment			
<b>Operating Humidity</b>	10% to 90% RH, non-condensing	<b>Operating Temperature</b>	0°C to 40°C
<b>Storage Temperature</b>	-20 °C to 60 °C		
Certification			
<b>Certification</b>	IEC 60601-1:2005 + A1:2012 (Ed. 3.1) IEC 60601-1-6:2010 + A1:2013 (Ed. 3.1) IEC 62366:2007 + A1:2014 (Ed. 1.1) ANSI/AAMI ES60601-1:2005/A1:2012 and C1:2009/(R)2012 and A2:2010/(R)2012 CAN/CSA-C22.2 No.60601-1:14 EN 60601-1-2:2015, IEC 60601-1-2:2014 (Ed. 4.0) EN 55032/EN 55024, FCC part 15B EN 62368-1:2014 RoHS-2, REACH, WEEE compliant		
IO Ports			
<b>USB Port</b>	1 x USB for Touch Screen	<b>Video</b>	1 x VGA 1 x HDMI (Optional)
<b>Audio</b>	1 x Audio In 2 x Speaker (Optional)		
Mechanical			
<b>Dimension</b>	388 x 233 x 40 mm	<b>Mounting</b>	VESA Mount
<b>Enclosure</b>	Plastic	<b>Cooling System</b>	Fanless Design
Accessory			
<b>Accessory</b>	1 x VGA cable 1 x HDMI cable 100~240V AC to DC Adapter Power Cord Manual VESA screws(Varies by product)		

## Power

Power Rating 12V DC input

## Control

Button 7 Keys: Enter, Exit, Right, Left, Up, Down, Power

## DIMENSIONS UNIT:MM

### 15.6" Multi-Touch Color Surgical Display W15L100-PTA3-ME

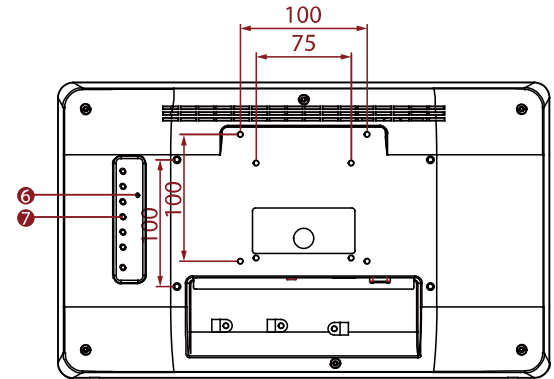
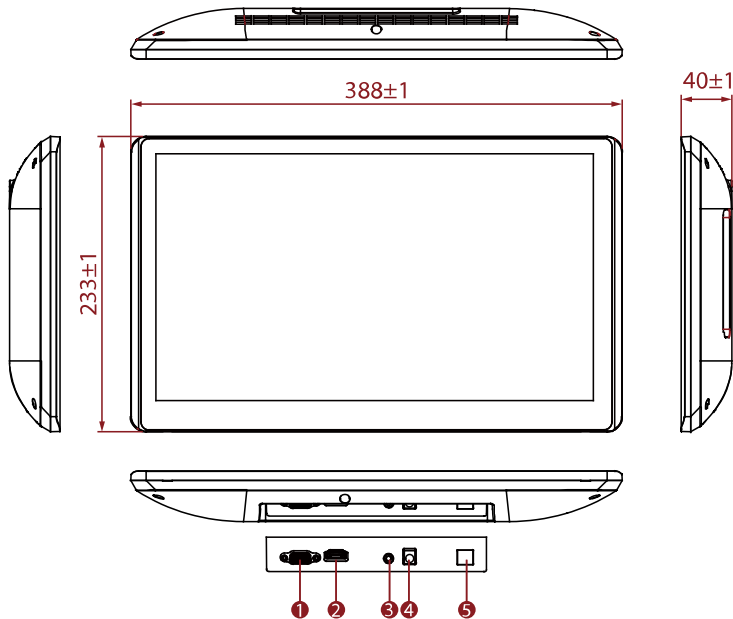

- ① VGA
- ② HDMI
- ③ Audio
- ④ Power Input
- ⑤ USB for Touch
- ⑥ LED Indicator
- ⑦ OSD Control Panel